



2583-26914-001 UNIVERSAL DISPLAY MOUNT, POLYCOM MEDIA CART

Polycom Media Cart offers utilitarian functionality at an affordable price, without sacrificing style. Media Cart's unique design, robust structure, and ease of mobility makes it particularly well suited for educational, as well as government or medical environments; but is also styled to fit beautifully in any conference room. Media Cart plays a valuable role in enhancing the video conferencing experience, supporting most flat panel displays ranging up to 60" in size.

Features:

1. Large, ventilated storage case with 19" wide opening.
2. Curved base with ventilation system.
3. Three interior shelves (3U spacing) to accommodate DVD/DVRs and other AV equipment.
4. Cable management features.
5. Durable 5" casters (locking on front, non-locking on rear).
6. Lockable, smoked acrylic (IR transparent) front door with tilt-up/slide-in hinge mechanism, providing easy access to AV equipment and storage.
7. Removable rear door with screw retainer.
8. Universal Mount to facilitate a wide range of flat panel display offerings.
9. Monitor height can be adjusted within a 6" range.
10. Sturdy post and cross bar to hold dual 37" to 42" flat panel displays; or single 37" to 60" flat panel displays





Specifications:

1. 4, 5" diameter industrial grade, black rubber casters with dark gray wheel hub and black painted metal 'fork'.
2. Product Weight (without LCD):
 - a. Single Mount – 65.6 Kgs
 - b. Dual Mount – 10.33 Kgs
 - c. Polycom Case - 12.02 Kgs
 - d. Polycom Case Gem Assy – 24.14 kgs
3. Shipping weights:
 - a. Cart assembly (includes base, case, and post subassemblies) – 109 lbs.
 - b. Universal Mount single – 17 lbs.
 - c. Universal Mount dual – 26 lbs.
4. Box Dimensions:
 - a. Single Mount – 53" X 36" X 64"
 - b. Dual Mount – 47" X 40" X 18"
5.  Safety considerations:
 - a. 125 pounds maximum weight for 1 flat panel 37-60" and 1 set of side-mount speakers
 - b. 125 pounds maximum weight for 2 flat panels 37-42" and 1 set of side-mount speakers
 - c. 200 pounds maximum weight for all additions to the product, both outside and inside. Includes display(s), speakers, codec, camera, camera mount, cables and other accessories.
6. Minimum display widths:
 - a. Single display is 32"
 - b. Dual displays is 80"

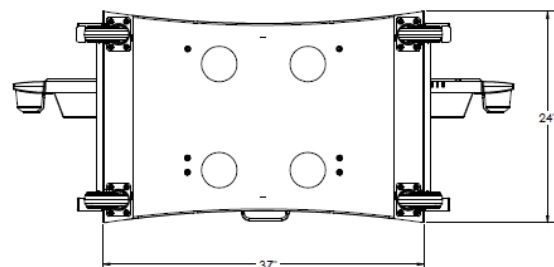
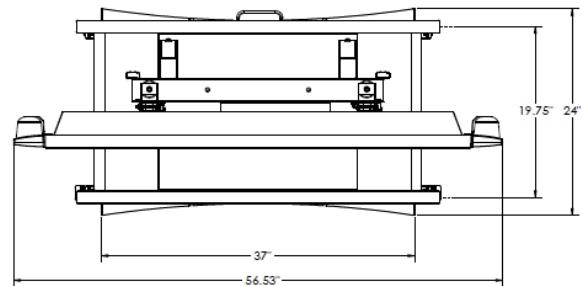
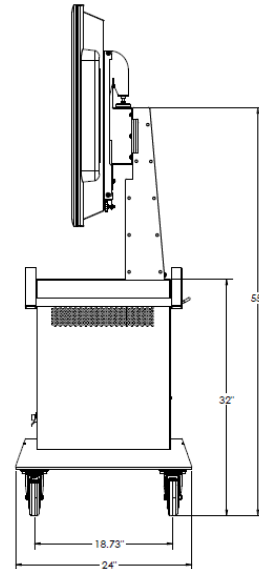
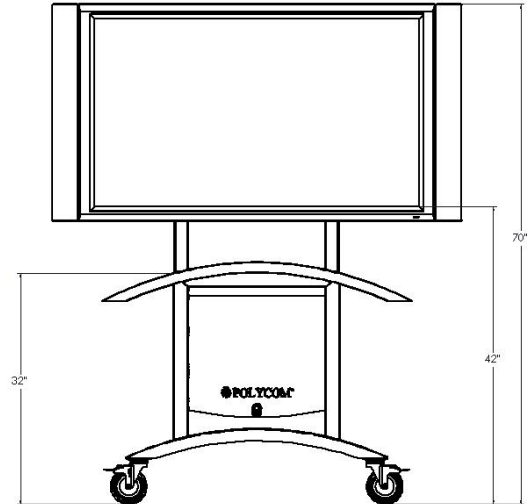



- Media Center showing dual display mounts position from the base.

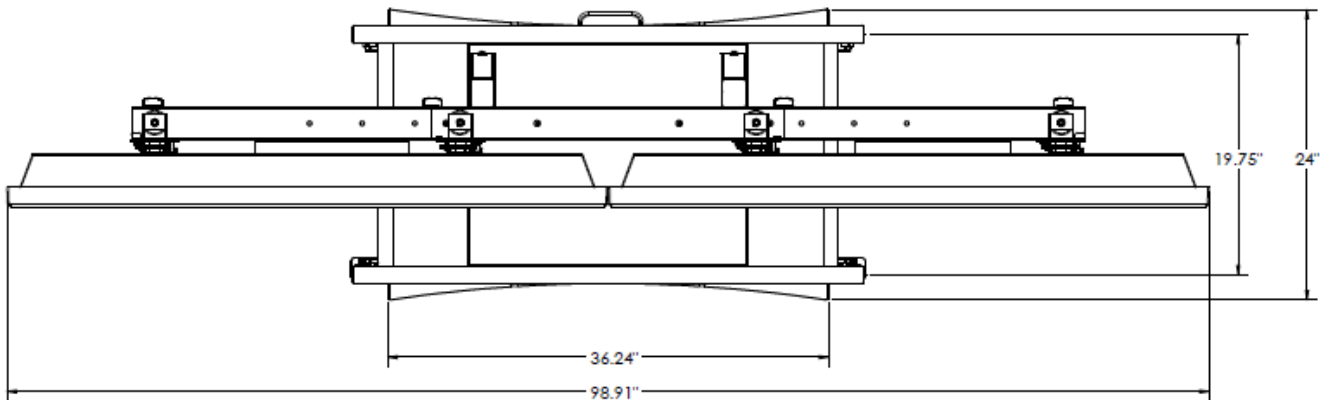
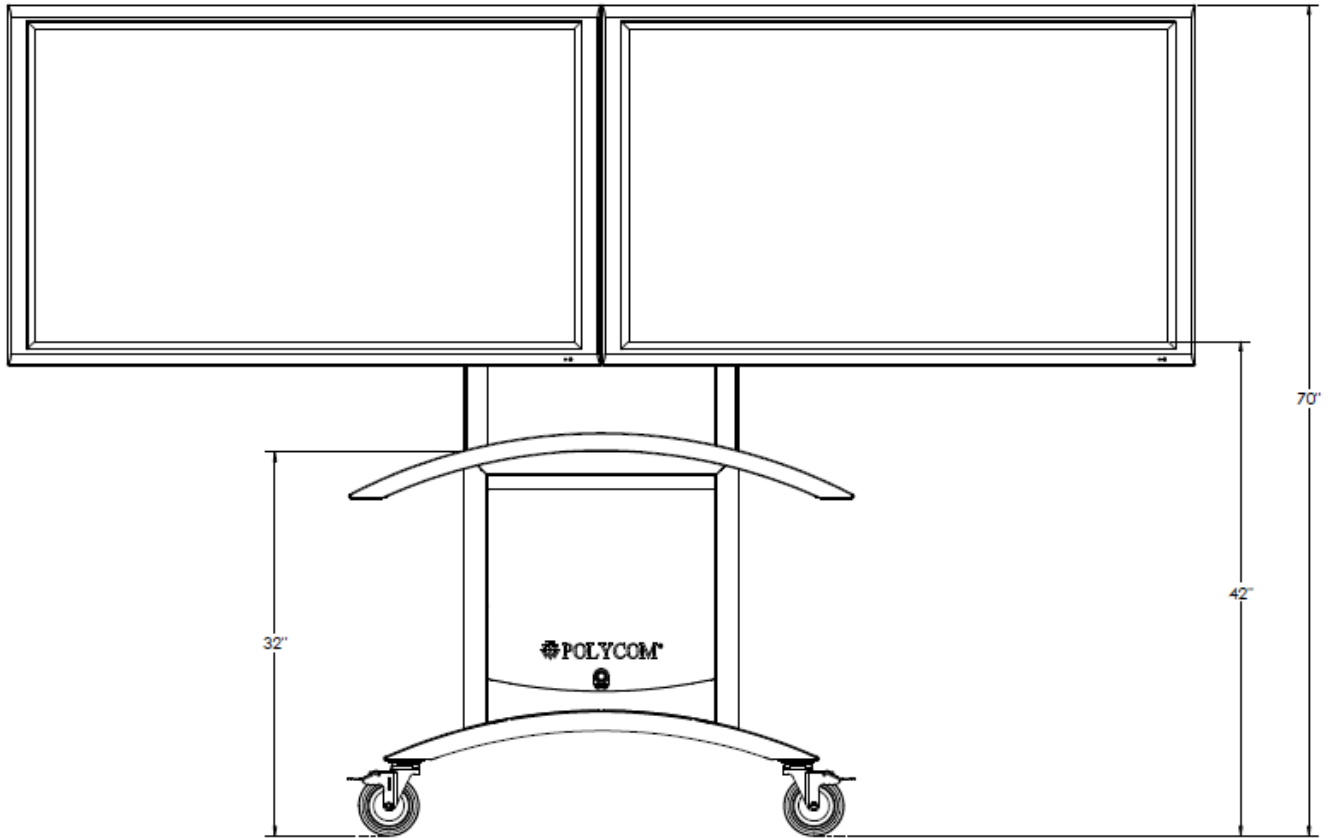



- Media Center showing single and dual horizontal rail position from the base.

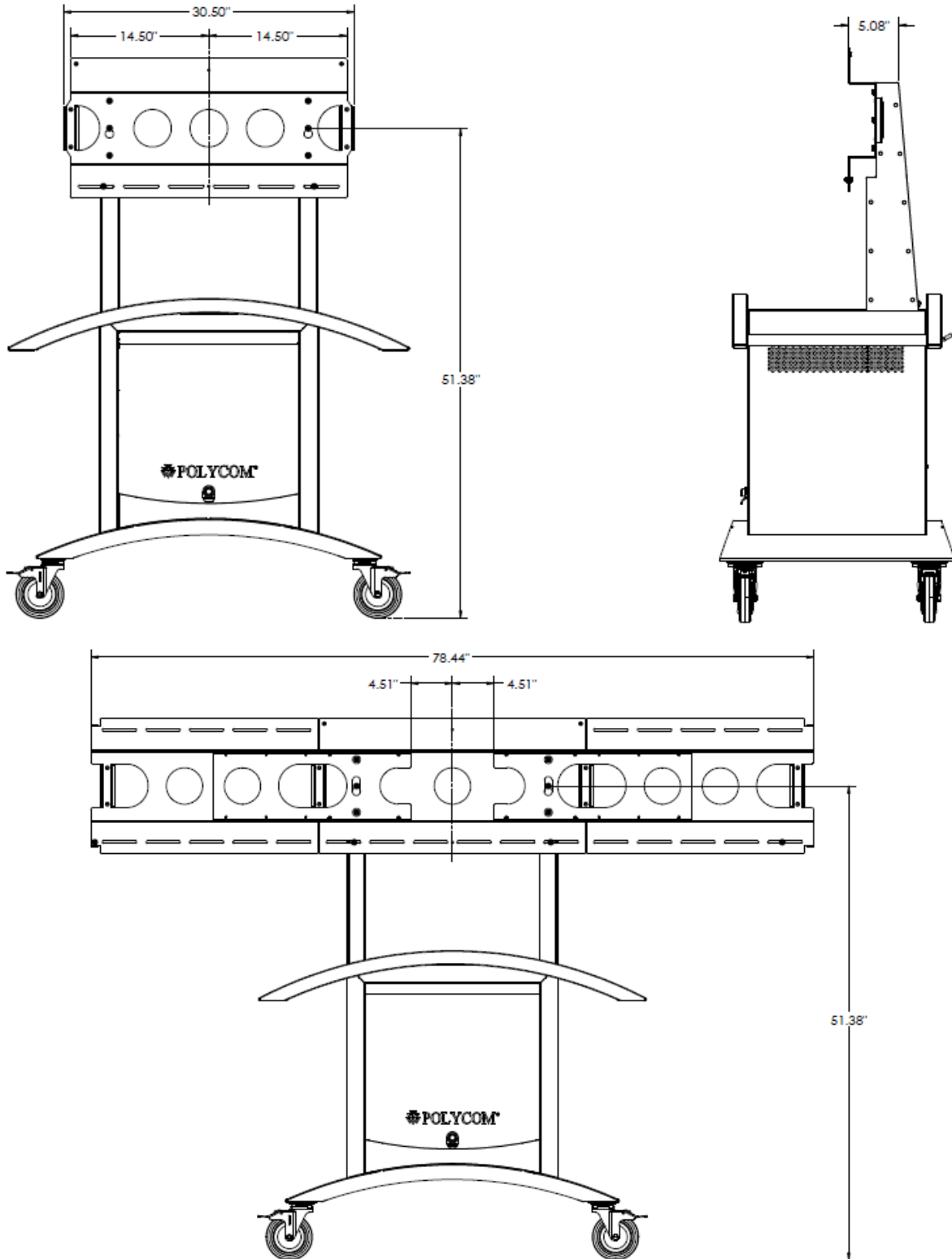

Subject to change without notice.



- Media Center Case showing holes pattern and spacing of the rack rails from the partition panel.

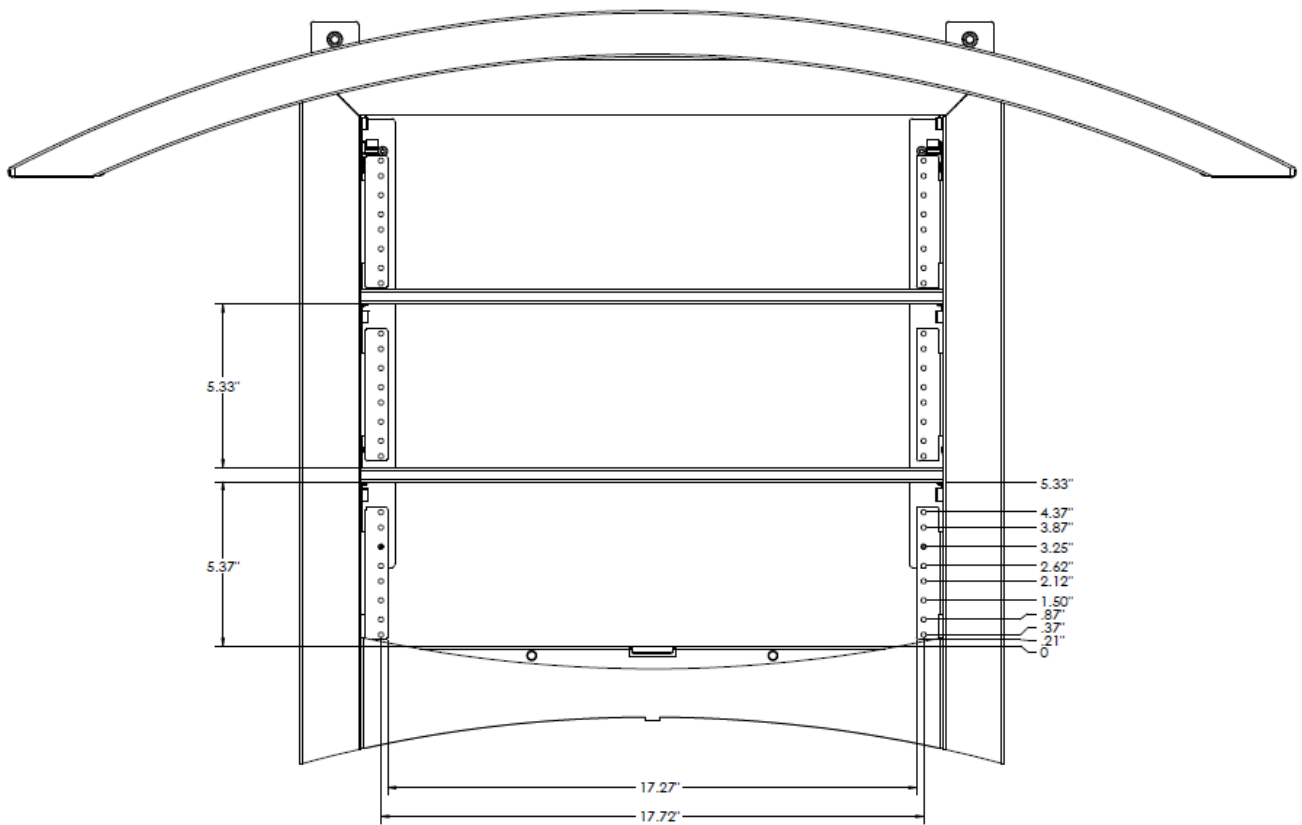



- Media Center showing vertical Interface bracket holes pattern and spacing for mounting different displays.

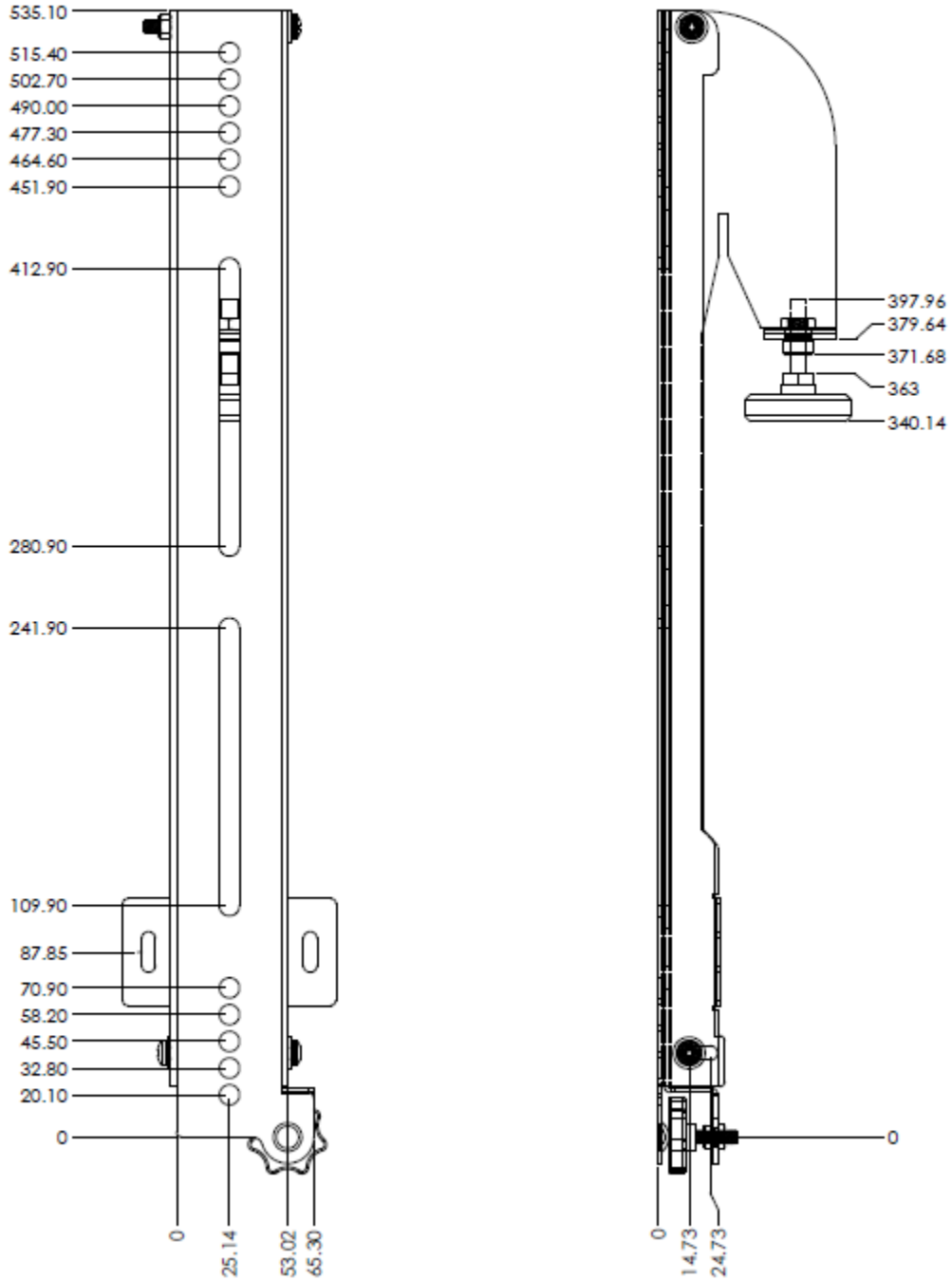

Polycom Media Cart orderable part numbers:	
2583-26914-001	Polycom Media Cart w/universal display mnt for 1 x 37"-60" flat panel,3-shelves,5" casters,adjustable monitor height, locking translucent front door, secure back panel, integrated cable mgnt. Order camera mnt, dual display mounts, rack mount separately
2215-26941-001	Polycom Media Cart dual display adapter kit. For use on 2583-26914-001 only. Support 2 37"-42" flat panel displays. Kit contains 2 extensions and hardware.
2215-26942-001	Polycom Media Cart rack mounting kit. Used with 2583-26914-001 to add rack mount capabilities to the inside shelves. Kit contains 6 3u rack adapters.
Other suggested items:	
2215-28283-001	Shelf for mounting the HDX 7000 and 8000 series codecs. This is a black 2u shelf for 19" racks which will hold the codec in position with a secure mounting system. 2u (3.5 inches) x 17.5 (without ears, 19 with) x 14.5 deep. Shelf only.
2215-24143-001	EagleEye HD and EagleEye QDX Camera wall/panel/shelf mounting bracket
2215-28765-001	EagleEye 1080 Camera wall/panel/shelf mounting bracket

